

**High Productivity Cooking
 Steam Tilting Boiling Pan, 60lt
 Freestanding, Hygienic profile -
 Electronic-Marine**

ITEM # _____

MODEL # _____

NAME # _____

SIS # _____

AIA # _____

587176 (PBOT06SCJO)

 Steam tilting Boiling Pan 60lt
 with electronic steam
 control, GuideYou panel,
 freestanding - Marine

Short Form Specification

Item No. _____

AISI 304 stainless steel construction. Deep drawn vessel in AISI 316 stainless steel. Insulated and counterbalanced lid. Motorized tilting with variable speed control. Pan can be tilted beyond 90° to completely empty the food. Food is uniformly heated via the base and the side walls of the pan by an indirect heating system using integrally generated saturated steam at a maximum temperature of 125°C in a jacket with an automatic deaeration system. Safety valve avoids overpressure of the steam in the jacket. Safety thermostat protects against low water level in the double jacket. TOUCH control panel. Possibility to store recipes in single or multiphase cooking process, with different temperature settings. Built in temperature sensors for precise control of cooking process. IPX6 water resistant. Configuration: Free-standing or Standing against a wall. Installation options (not included): floor mounted on 200mm high feet or a plinth which can be either steel or masonry construction.

Main Features

- Kettle is suitable to boil, steam, poach, braise or simmer all kinds of produce.
- Produce is uniformly heated in the vessel by an indirect heating system using saturated steam.
- Kettle is jacketed up to 134 mm from upper rim.
- Isolated upper well rim avoids risk of harm for the user.
- Max pressure of inner jacket at 1,5 bar; minimum working pressure at 0.5 bar.
- Ergonomic vessel dimensions, with a large diameter and shallow depth facilitates stirring and gentle food handling.
- Edge of the large pouring lip can be equipped with a strainer (option).
- Built in temperature sensor to precisely control the cooking process.
- Motorized, variable pan tilting with "SOFT STOP". Tilting and pouring speeds can be precisely adjusted. Pan can be tilted over 90° to facilitate pouring and cleaning operations.
- USB connection to easily update the software, upload/download recipes and download HACCP data.
- IPX6 water resistant.

Construction

- Cooking vessel in 1.4435 (AISI 316L) stainless steel featuring directional pouring lip. Double-jacket in 1.4404 (AISI 316L) stainless steel designed to operate at a pressure of 1.5 bar.
- External panelling and internal frame made of 1.4301 (AISI 304) stainless steel.
- Double-lined insulated lid in 1.4301 (AISI 304) stainless steel mounted on the cross beam of the unit, counterbalanced by a hinge that remains open in all positions.
- Safety valve avoids overpressure of the steam in the double jacket.
- External steam feeding; 1,5 bars working pressure.
- Safety thermostat protects against low water level in the double jacket.
- Water mixing tap is available as optional accessory to make water filling and pan cleaning easier.
- Ergonomic and user friendly thanks to the high tilting position and the pouring lip design which allow to easily fill containers.
- Front-mounted inclined led "TOUCH" control panel with recessed deep drawn casing, features self-explanatory display functions which guide operator throughout the cooking process: simultaneous display of actual and set temperature as well as set cooking time

APPROVAL: _____

and remaining cooking time; real time clock; "SOFT" control for gentle heating up for delicate food; 9 power simmering levels from gentle to heavy boiling; timer for deferred start; error display for quick trouble-shooting.

- Minimised presence of narrow gaps for easier cleaning of the sides to meet the highest hygiene standards.
- Can be prearranged for energy optimisation or external surveillance systems (optional).
- Possibility to store recipes in single or multiphase cooking process, with different temperature settings.
- 98% recyclable by weight; packaging material free of toxic substances.
- GuideYou Panel - activated by the user via settings - to easily follow the multiphase recipes, granting a proper and controlled cooking and a better appliance optimization.
The system will provide maintenance reminders, in line with ESSENTIA program, helping the user to properly take care of the product, avoiding downtimes.
- Highly-visible and bright led TOUCH control panel features user-friendly icons and intuitive self-explanatory command options. Display visualizes:
 - Actual and set temperature
 - Set and remaining cooking time
 - Pre-heating phase (if activated)
 - GuideYou Panel (if activated)
 - Deferred start
 - Soft Function to reach the target temperature smoothly
 - 9 Power Control levels from simmering to fierce boiling
 - Pressure mode (in pressure models)
 - Stirrer ON/OFF settings (in round boiling models)
 - Error codes for quick trouble-shooting
 - Maintenance reminders

- | | | |
|--|------------|--------------------------|
| • Connecting rail kit for appliances with backsplash, 900mm | PNC 912499 | <input type="checkbox"/> |
| • Connecting rail kit, 900mm | PNC 912502 | <input type="checkbox"/> |
| • Automatic water filling (hot and cold) for tilting units - to be ordered with water mixer - factory fitted | PNC 912735 | <input type="checkbox"/> |
| • Kit energy optimization and potential free contact - factory fitted | PNC 912737 | <input type="checkbox"/> |
| • Mainswitch 25A, 2.5mm ² - factory fitted | PNC 912739 | <input type="checkbox"/> |
| • Rear closing kit for tilting units - island type - factory fitted | PNC 912743 | <input type="checkbox"/> |
| • Lower rear backpanel for tilting units with or without backsplash - factory fitted | PNC 912767 | <input type="checkbox"/> |
| • Spray gun for tilting units - freestanding (height 700mm) - factory fitted | PNC 912776 | <input type="checkbox"/> |
| • Food tap 2" for tilting boiling pans (PBOT) - factory fitted | PNC 912779 | <input type="checkbox"/> |
| • Emergency stop button - factory fitted | PNC 912784 | <input type="checkbox"/> |
| • Mixing tap with drip stop, two knobs, 685mm height, 600mm swivelling depth for PBOT/PFET - factory fitted | PNC 913556 | <input type="checkbox"/> |
| • Connectivity kit for ProThermetic Boiling and Braising Pans ECAP - factory fitted | PNC 913577 | <input type="checkbox"/> |

User Interface & Data Management

- Connectivity ready for real time access to connected appliances from remote and data monitoring (requires optional accessory - contact the Company for more details).

Included Accessories

- 1 of Rear closing kit for tilting units - PNC 912703 against wall - factory fitted

Optional Accessories

- | | | |
|--|------------|--------------------------|
| • Strainer for 40 and 60lt tilting boiling pans | PNC 910001 | <input type="checkbox"/> |
| • Basket for 60lt stationary boiling pans (diam. 480mm) | PNC 910021 | <input type="checkbox"/> |
| • Base plate for 60lt tilting boiling pans | PNC 910031 | <input type="checkbox"/> |
| • Measuring rod for 60lt tilting boiling pans | PNC 910042 | <input type="checkbox"/> |
| • Food tap strainer for tilting boiling pans | PNC 911966 | <input type="checkbox"/> |
| • C-board (length 1100mm) for tilting units - factory fitted | PNC 912183 | <input type="checkbox"/> |

Front

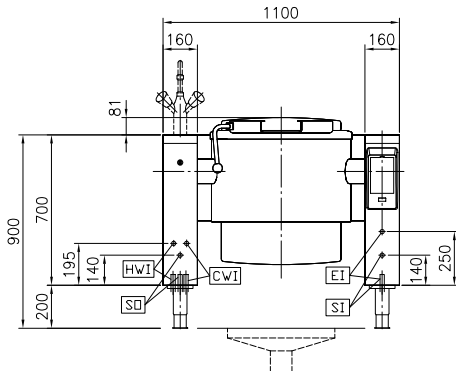

Side

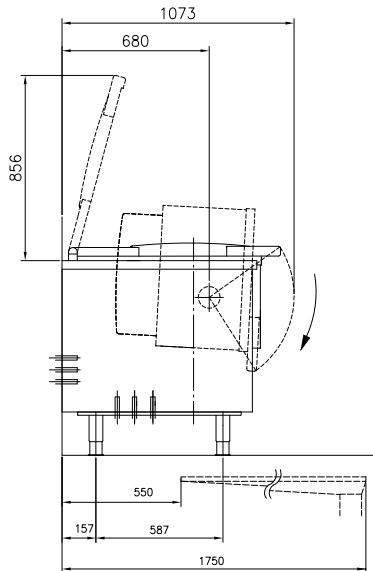

CWI = Cold Water inlet 1 (cleaning) SO = Steam outlet
 EI = Electrical inlet (power)
 HWI = Hot water inlet
 SI = Steam inlet

Top

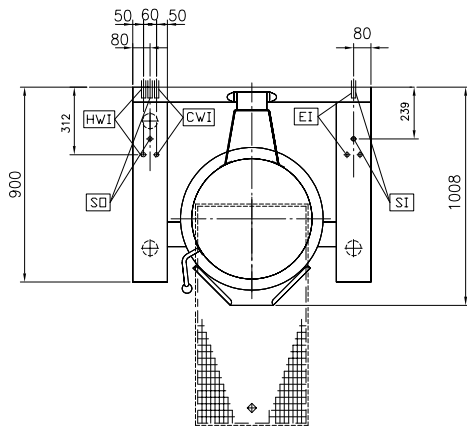

Electric

Supply voltage: 230 V/1 ph/50/60 Hz
Total Watts: 0.2 kW

Steam

Steam generation: External source
Steam inlet size: 3/4"
Steam pressure Max: 1.5 bar
Steam supply, relative dynamic pressure: 1 min bar, 1.5 max bar

Water:

Pressure, min-max: 2-6 bar

Installation:

FS on concrete base; FS on feet; On base; Standing against wall

Type of installation:

Key Information:

Working Temperature MIN: 50 °C
Working Temperature MAX: 110 °C
Vessel (round) diameter: 579 mm
Vessel (round) depth: 385 mm
External dimensions, Width: 1100 mm
External dimensions, Depth: 900 mm
External dimensions, Height: 700 mm
Net weight: 170 kg
Configuration: Round; Tilting
Net vessel useful capacity: 60 lt
Tilting mechanism: Automatic
Double jacketed lid: ✓
Heating type: Indirect

Sustainability

Steam consumption: 40 kg/hr